

5F.2 SET MANOEUVRE DRAWINGS

Set Manoeuvres 1 – 18 (of 30)

1. Inside loop K 3.5

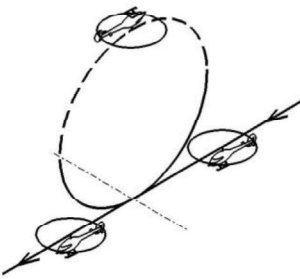

2. Inverted pirouette K 5

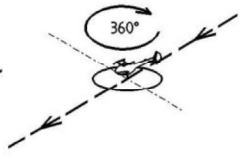

3. Backward circle K 4

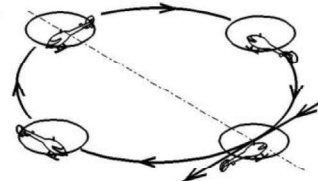

4. Double Immelmann K 4

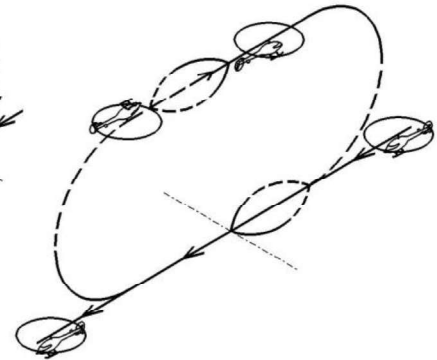

6. 4-point-roll K 4.5

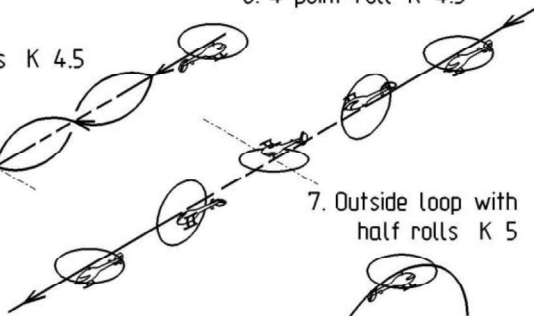

5. Double roll backwards K 4.5

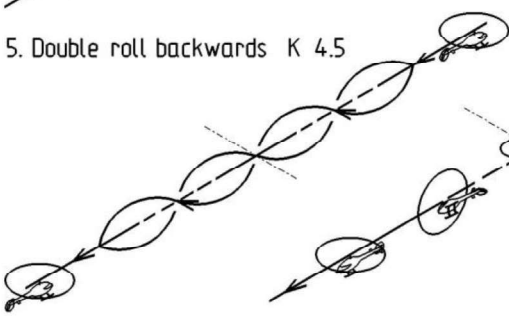

7. Outside loop with half rolls K 5



8. Inverted horizontal eight K 5

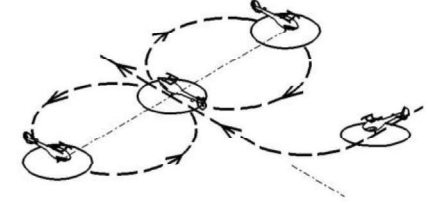

9. Backward knife edge pirouette K 5.5

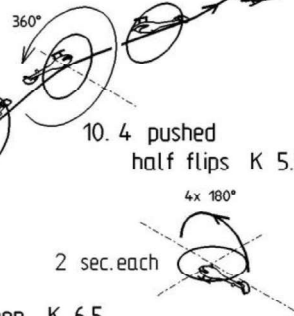

10. 4 pushed half flips K 5.5

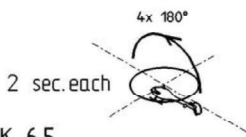

11. TicToc K 6

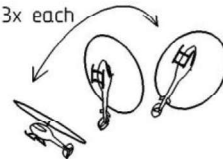

12. 360°-turn with roll K 6

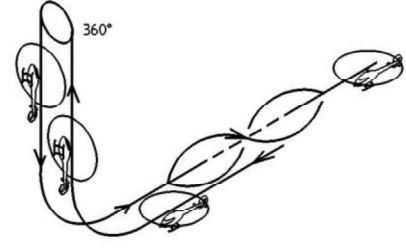

13. Backward loop K 6.5

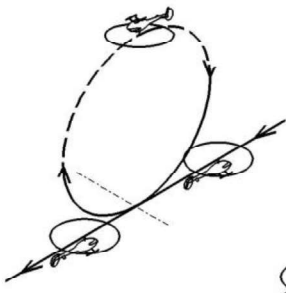

14. 4-point roll backwards K 6.5

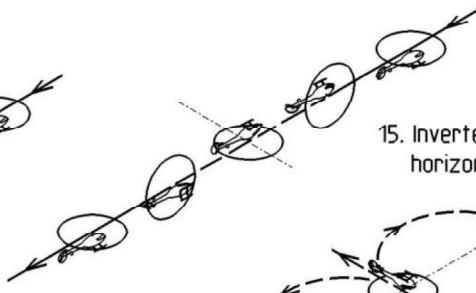

15. Inverted backwards horizontal eight K 7

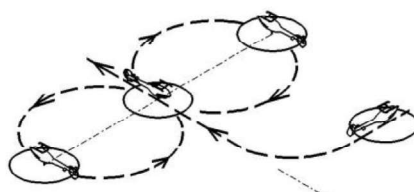

16. Rolling circle K 7.5

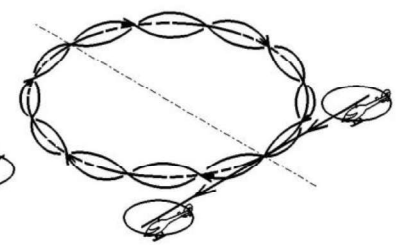

17. 4 rainbows with half rolls K 7.5

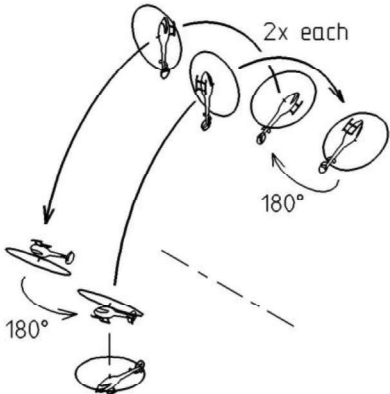

18. Funnel K 7.5

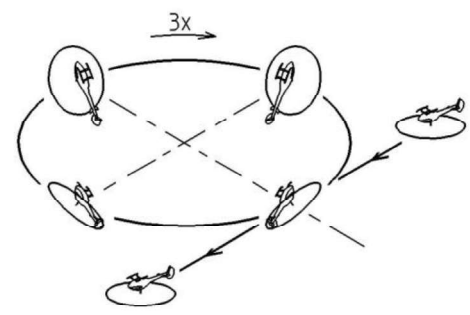

Set Manoeuvres 19 – 30.

